

- NOTES:
- 1) HOISTWAY DIMENSIONS ARE MINIMUM CLEAR INSIDE DIMENSIONS.
  - 2) FOR SEISMIC ZONES 2 AND UP, ADD 4" TO HOISTWAY WIDTH.
  - 3) THIS CAR IS NOT 24"x84" GURNEY COMPLIANT.

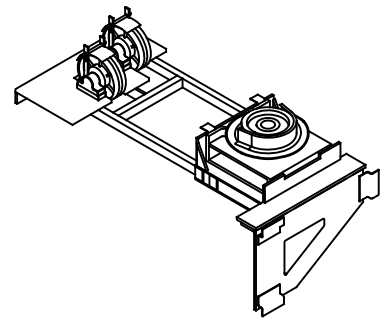

# HOISTWAY PLAN

# OVERHEAD MACHINE DETAIL

TRACTION MRL: RAIL SUPPORTED  
3000 LB SSSO (RH)

**NOT FOR CONSTRUCTION**

**ALLIANCE**  
ELEVATOR SOLUTIONS  
335 NOVA DR.  
GREENCASTLE, PA 17225

N.T.S.	1 OF 3	2023
--------	--------	------