

NOTES:

- 1) HOISTWAY DIMENSIONS ARE MINIMUM CLEAR INSIDE DIMENSIONS.
- 2) FOR SEISMIC ZONES 2 AND UP, ADD 4" TO HOISTWAY WIDTH.
- 3) THIS CAR IS NOT 24"x84" GURNEY COMPLIANT.

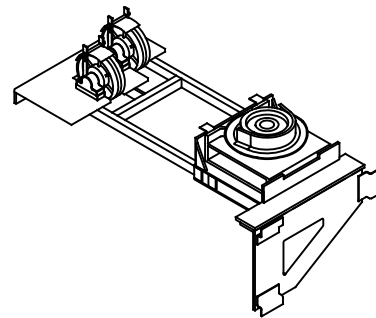

HOISTWAY PLAN

OVERHEAD MACHINE DETAIL

TRACTION MRL: RAIL SUPPORTED
2100 LB SSSO (RH)

NOT FOR CONSTRUCTION

ALLIANCE
ELEVATOR SOLUTIONS

335 NOVA DR.
GREENCASTLE, PA 17225

N.T.S.

1 OF 2

2023