

- NOTES:
- 1) HOISTWAY DIMENSIONS ARE MINIMUM CLEAR INSIDE DIMENSIONS.
 - 2) FOR SEISMIC ZONES 2 AND UP, ADD 4" TO HOISTWAY WIDTH.
 - 3) THIS CAR IS NOT 24"x84" GURNEY COMPLIANT.

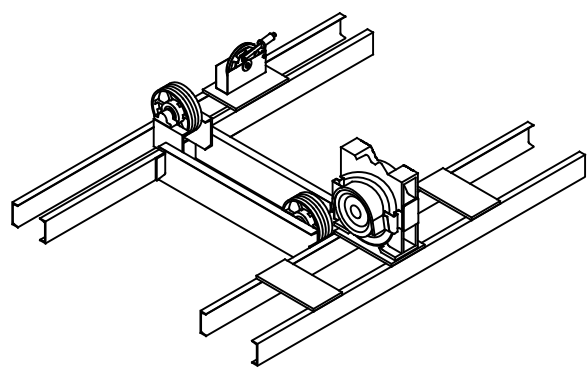
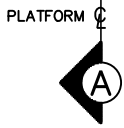

HOISTWAY PLAN

OVERHEAD MACHINE DETAIL

TRACTION MRL:
BLDG SUPPORTED
3000 LB SSSO (RH)

NOT FOR CONSTRUCTION

ALLIANCE
ELEVATOR SOLUTIONS
335 NOVA DR.
GREENCASTLE, PA 17225

N.T.S.	1 OF 3	2023
--------	--------	------