

NOTES:

- 1) HOISTWAY DIMENSIONS ARE MINIMUM CLEAR INSIDE DIMENSIONS.
- 2) FOR SEISMIC ZONES 2 AND UP, ADD 4" TO HOISTWAY WIDTH.

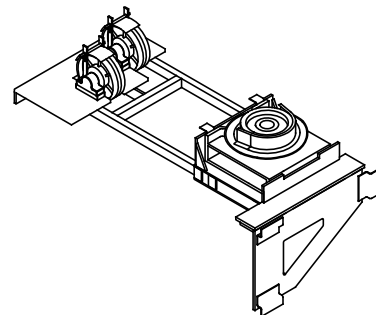

HOISTWAY PLAN

OVERHEAD MACHINE DETAIL

TRACTION MRL: RAIL SUPPORTED
2100 LB SSSO (RH)

NOT FOR CONSTRUCTION

ALLIANCE
ELEVATOR SOLUTIONS
237 OREGON ST.
MERCERSBURG, PA 17236

N.T.S.	1 OF 2	2020
--------	--------	------

WHEN NO FULLY BODY ENTRY INTO OVERHEAD, GOVERNOR AND MACHINE BRAKE REQUIRE 24" x 24" ACCESS DOOR

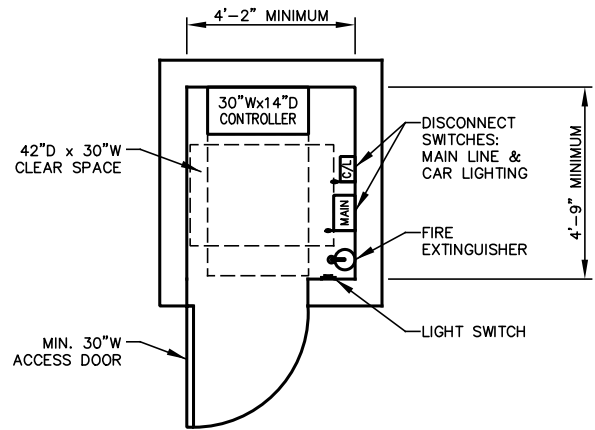
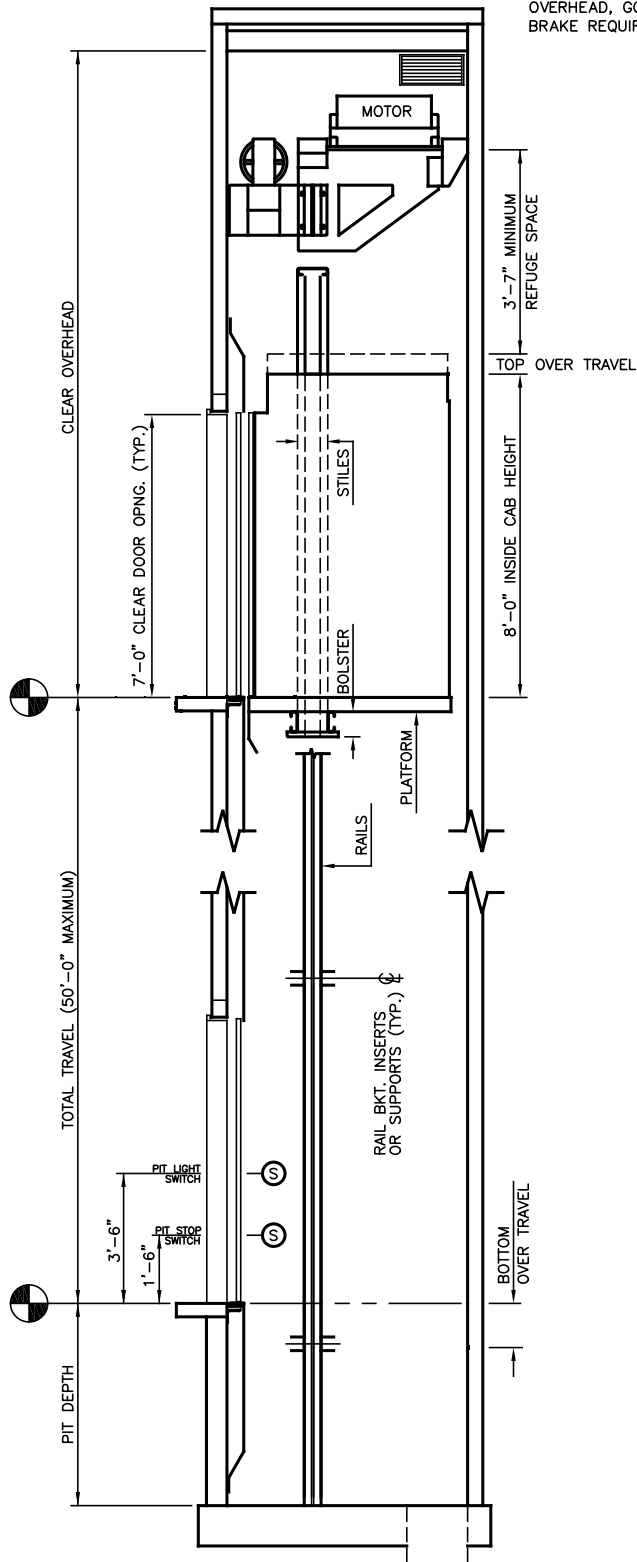

CONTROLLER ROOM

BY DEFAULT CONTROLLER ROOM IS LOCATED ON THE TOP LANDING ADJACENT TO THE HOISTWAY

PIT & OVERHEAD BASED ON CAR SPEED AND CAPACITY

SPEED (FPM)	PIT	CAPACITY (LB)			
		2100	2500	3000	3500
100	5'-0"	14'-5"	14'-5"	14'-9"	14'-9"
150	5'-0"	14'-5"	14'-5"	14'-9"	14'-9"
200	5'-0"	14'-9"	14'-9"	14'-10"	14'-10"
250	5'-6"	14'-10"	14'-10"	14'-11"	14'-11"
300	5'-6"	14'-11"	14'-11"	15'-0"	15'-0"
350	5'-6"	15'-5"	15'-5"	15'-6"	15'-6"

NOTE: OIL BUFFERS REQUIRED FOR CAR SPEED ABOVE 200 FPM. SPRING BUFFERS MAY BE USED FOR 200 FPM AND BELOW.

SECTION "A"

NOT FOR CONSTRUCTION

ALLIANCE
ELEVATOR SOLUTIONS
237 OREGON ST.
MERCERSBURG, PA 17236